

DIESEL | LPG

Linde Material Handling

Linde



Internal Combustion Engine Counterbalance Truck

H50 – H80 EVO

Capacity 5.0 – 8.0 t | Series 396

Sustained performance

- Top operating performance for large loads by means of powerful engines and lift mast control system
- Improved visibility through slim lift mast profile
- Minimal service times due to hydrostatic drive – no transmission, clutch, differential or drum brakes
- Safe and quick load handling due to 30% reduction in lift mast torsion
- Shifting roof-mounted steel grid protects driver from falling loads when mast tilted

TECHNICAL DATA (According to VDI 2198)

	Characteristics						
	1.1	Manufacturer	Linde	Linde	Linde	Linde	
	1.2	Model	H50 D	H60 D	H70 D	H80 D	
	1.2a	Series	396-03	396-03	396-03	396-03	
	1.3	Power unit	Diesel	Diesel	Diesel	Diesel	
	1.4	Operation	Seat	Seat	Seat	Seat	
	1.5	Load capacity/Load	Q (t)	5.0	6.0	7.0	8.0
	1.6	Load centre	c (mm)	600	600	600	600
	1.8	Axle centre to fork face	x (mm)	630	630	640	640
	1.9	Wheelbase	y (mm)	2200	2200	2200	2200
Weights	2.1	Service weight	(kg)	10105	10169	11381	12335
	2.2	Axle load with load, front/rear	(kg)	12689/2416	14250/1919	15995/2386	17844/2491
	2.3	Axle load without load, front/rear	(kg)	4894/5211	4895/5274	5050/6331	5335/7000
Wheels/Tyres	3.1	Tyres rubber, SE, pneumatic, polyurethane	SE	SE	SE twin	SE twin	
	3.2	Tyre size, front	355/65 - 15	355/65 - 15	8.25 - 15	8.25 - 15	
	3.3	Tyre size, rear	8.25 - 15	8.25 - 15	315/70 - 15 (300 - 15)	315/70 - 15 (300 - 15)	
	3.5	Wheels, number front/rear (x = driven)	2x/2	2x/2	4x/2	4x/2	
	3.6	Track width, front	b10 (mm)	1594	1594	1742	1742
	3.7	Track width, rear	b11 (mm)	1600	1600	1550	1550
Dimensions	4.1	Mast/fork carriage tilt, forward/backward	a/b (°)	5.0/9.0	5.0/9.0	5.0/9.0	5.0/9.0
	4.2	Height of mast, lowered	h1 (mm)	2735 ¹⁾	2,735 ¹⁾	2738 ¹⁾	2737 ¹⁾
	4.3	Free lift	h2 (mm)	150	150	150	150
	4.4	Lift	h3 (mm)	3550 ²⁾	3,550 ²⁾	3150 ²⁾	3150 ²⁾
	4.5	Height of mast, extended	h4 (mm)	4448	4448	4245	4244
	4.7	Height of overhead guard (cabin)	h6 (mm)	2746	2746	2748	2746
	4.8	Seat height relative to SIP/stand height	h7 (mm)	1507	1507	1509	1508
	4.12	Towing coupling height	h10 (mm)	830	830	830	828
	4.19	Overall length	l1 (mm)	4719	4719	4729	4729
	4.20	Length to fork face	l2 (mm)	3519	3519	3529	3529
	4.21	Overall width	b1/b2 (mm)	1900/1870 ³⁾	1900/1870 ³⁾	2232/1870 ³⁾	2232/1870 ³⁾
	4.22	Fork dimensions DIN ISO 2331	s/e/l (mm)	60 × 130 × 1200	60 × 130 × 1200	70 × 150 × 1200	70 × 150 × 1200
	4.23	Fork carriage to ISO 2328, class/type A, B		4A	4A	4A	4A
	4.24	Width of fork carriage	b3 (mm)	1800	1800	1800	2180
	4.31	Ground clearance, below mast	m1 (mm)	208	204	208	204
	4.32	Ground clearance, centre of wheelbase	m2 (mm)	250	249	251	250
	4.33	Load dimension b12 × l6	b12 × l6 (mm)	-	-	-	-
	4.34	Aisle width predetermined load dimensions	Ast (mm)	-	-	-	-
	4.34.1	Aisle width for pallets 1000 × 1200 crossways	Ast (mm)	5016 ⁴⁾	5016 ⁴⁾	5026 ⁴⁾	5026 ⁴⁾
	4.34.2	Aisle width with pallet 800 × 1200 along forks	Ast (mm)	5216 ⁴⁾	5216 ⁴⁾	5226 ⁴⁾	5226 ⁴⁾
4.35	Turning radius	Wa (mm)	3186	3186	3186	3186	
4.36	Minimum pivoting point distance	b13 (mm)	1061	1061	1061	1061	
Performance	5.1	Travel speed, with/without load	(km/h)	22/23	22/23	22/23	22/23
	5.2	Lifting speed, with/without load	(m/s)	0.54/0.54	0.54/0.54	0.49/0.53	0.49/0.53
	5.3	Lowering speed, with/without load	(m/s)	0.54/0.5	0.54/0.5	0.56/0.45	0.56/0.45
	5.5	Tractive force, with/without load	(N)	50000/35000	50000/35000	50000/37000	51000/41000
	5.7	Climbing ability, with/without load	(%)	32.0/36.0	30.0/36.0	28.0/35.0	26.0/34.0
	5.9	Acceleration time, with/without load	(s)	5.4/4.8	5.6/5.0	5.7/5.1	5.8/5.2
5.10	Service brake		hydrostatic	hydrostatic	hydrostatic	hydrostatic	
IC-Drive	7.1	Engine manufacturer/type		Deutz TCD 4.1 L4	Deutz TCD 4.1 L4	Deutz TCD 4.1 L4	Deutz TCD 4.1 L4
	7.2	Engine performance according to DIN ISO 1585	(kW)	85	85	85	85
	7.3	Rated speed	(1/min)	2200	2200	2200	2200
	7.4	Number of cylinders/displacement	(- / cm ³)	4/4038	4/4038	4/4038	4/4038
	7.5	Fuel consumption according to DIN EN 16796	(l/h)	5 ⁵⁾	5.3 ⁵⁾	5.6 ⁵⁾	6 ⁵⁾
	7.5.1	CO ₂ equivalent according to EN 16796	kg/h	15.9	16.8	17.8	19.1
	7.6	Turnover output according to VDI 2198	t/h	365.0	440.0	517.0	594.0
7.7	Turnover efficiency according to VDI 2198	t/l	39.7	44.4	48.3	51.7	
Drive/Lift mechanism	8.1	Type of drive control		hydrost./stepl.	hydrost./stepl.	hydrost./stepl.	hydrost./stepl.
	10.1	Operating pressure for attachments	(bar)	265	265	265	265
	10.2	Oil flow for attachments	(l/min)	95	95	95	95
	10.7	Sound pressure level LpAZ (at the driver's seat)	(dB(A))	77	77	77	77
	10.8	Towing coupling, design/type, DIN 15 170		similar to form H	similar to form H	similar to form H	similar to form H

1) With 150 mm free lift 2) For alternative masts, refer to tables 3) front/rear 4) Including a 200 mm (min.) operating aisle clearance 5) Power consumption with 45 working cycles per hour

TECHNICAL DATA (According to VDI 2198)

	Characteristics						
	1.1	Manufacturer	Linde	Linde	Linde	Linde	
	1.2	Model	H80/900 D	H80/1100 D	H50 T	H60 T	
Weights	1.2a	Series	396-03	396-03	396-03	396-03	
	1.3	Power unit	Diesel	Diesel	LPG	LPG	
	1.4	Operation	Seat	Seat	Seat	Seat	
	1.5	Load capacity/Load	Q (t)	8.0	8.0	5.0	6.0
	1.6	Load centre	c (mm)	900	1100	600	600
	1.8	Axle centre to fork face	x (mm)	670	680	630	630
	1.9	Wheelbase	y (mm)	2510	2810	2200	2200
	2.1	Service weight	(kg)	14039	14873	9980	10031
	2.2	Axle load with load, front/rear	(kg)	19725/2314	20586/2287	12504/2476	14030/2001
2.3	Axle load without load, front/rear	(kg)	6721/7318	7518/7355	4709/5271	4675/5356	
Wheels/Tyres	3.1	Tyres rubber, SE, pneumatic, polyurethane	SE twin	SE twin	SE	SE	
	3.2	Tyre size, front	8.25 - 15	315/70 - 15 (300 - 15)	355/65 - 15	355/65 - 15	
	3.3	Tyre size, rear	315/70 - 15 (300 - 15)	315/70 - 15 (300 - 15)	8.25 - 15	8.25 - 15	
	3.5	Wheels, number front/rear (x = driven)	4x/2	4x/2	2x/2	2x/2	
	3.6	Track width, front	b10 (mm)	1742	1752	1594	1594
	3.7	Track width, rear	b11 (mm)	1550	1550	1600	1600
	Dimensions	4.1	Mast/fork carriage tilt, forward/backward	a/b (°)	5.0/9.0	5.0/9.0	5.0/9.0
4.2		Height of mast, lowered	h1 (mm)	2735 ¹⁾	2737 ¹⁾	2735 ¹⁾	2735 ¹⁾
4.3		Free lift	h2 (mm)	150	150	150	150
4.4		Lift	h3 (mm)	2750 ²⁾	2750 ²⁾	3550 ²⁾	3550 ²⁾
4.5		Height of mast, extended	h4 (mm)	4144	4146	4448	4448
4.7		Height of overhead guard (cabin)	h6 (mm)	2746	2747	2746	2746
4.8		Seat height relative to SIP/stand height	h7 (mm)	1507	1508	1507	1507
4.12		Towing coupling height	h10 (mm)	828	827	830	830
4.19		Overall length	l1 (mm)	5629	6339	4719	4719
4.20		Length to fork face	l2 (mm)	3829	4139	3519	3519
4.21		Overall width	b1/b2 (mm)	2232/1870 ³⁾	2305/1870 ³⁾	1900/1870 ³⁾	1900/1870 ³⁾
4.22		Fork dimensions DIN ISO 2331	s/e/l (mm)	70 × 200 × 1800	80 × 200 × 2200	60 × 130 × 1200	60 × 130 × 1200
4.23		Fork carriage to ISO 2328, class/type A, B		4A	4A	4A	4A
4.24		Width of fork carriage	b3 (mm)	2180	2400	1800	1800
4.31		Ground clearance, below mast	m1 (mm)	201	208	208	204
4.32		Ground clearance, centre of wheelbase	m2 (mm)	248	250	250	249
4.33		Load dimension b12 × l6	b12 × l6 (mm)	2000 × 2200	2000 × 2200	-	-
4.34		Aisle width predetermined load dimensions	Ast (mm)	6580	6930	-	-
4.34.1		Aisle width for pallets 1000 × 1200 crossways	Ast (mm)	5380 ⁴⁾	5730 ⁴⁾	5016 ⁴⁾	5016 ⁴⁾
4.34.2		Aisle width with pallet 800 × 1200 along forks	Ast (mm)	5580 ⁴⁾	5930 ⁴⁾	5216 ⁴⁾	5216 ⁴⁾
4.35	Turning radius	Wa (mm)	3510	3850	3186	3186	
4.36	Minimum pivoting point distance	b13 (mm)	1240	1410	1061	1061	
Performance	5.1	Travel speed, with/without load	(km/h)	22/23	22/23	22/23	22/23
	5.2	Lifting speed, with/without load	(m/s)	0.49/0.53	0.49/0.53	0.51/0.53	0.51/0.53
	5.3	Lowering speed, with/without load	(m/s)	0.56/0.45	0.56/0.45	0.5/0.5	0.5/0.5
	5.5	Tractive force, with/without load	(N)	52000/46000	54000/50000	50000/35000	50000/35000
	5.7	Climbing ability, with/without load	(%)	24.0/34.0	23.0/34.0	32.0/35.0	30.0/35.0
	5.9	Acceleration time, with/without load	(s)	6.0/5.2	6.1/5.3	6.2/5.2	6.4/5.4
5.10	Service brake		hydrostatic	hydrostatic	hydrostatic	hydrostatic	
IC-Drive	7.1	Engine manufacturer/type		Deutz TCD 4.1 L4	Deutz TCD 4.1 L4	VW CKPA	VW CKPA
	7.2	Engine performance according to DIN ISO 1585	(kW)	85	85	72	72
	7.3	Rated speed	(1/min)	2200	2200	2500	2500
	7.4	Number of cylinders/displacement	(-/cm ³)	4/4038	4/4038	6/3597	6/3597
	7.5	Fuel consumption according to DIN EN 16796	(l/h)	6 ⁵⁾	6.1 ⁵⁾	4.7 ⁵⁾	5 ⁵⁾
	7.5.1	CO ₂ equivalent according to EN 16796	kg/h	19.1	19.4	15.9	16.8
	7.6	Turnover output according to VDI 2198	t/h	590.0	586.0	362.0	426.0
	7.7	Turnover efficiency according to VDI 2198	t/l	51.3	51	44.7	52.6
Drive/Lift mechanism	8.1	Type of drive control		hydrost./stepl.	hydrost./stepl.	hydrost./stepl.	hydrost./stepl.
	10.1	Operating pressure for attachments	(bar)	265	265	265	265
	10.2	Oil flow for attachments	(l/min)	95	95	95	95
	10.7	Sound pressure level LpAZ (at the driver's seat)	(dB(A))	77	77	76	76
	10.8	Towing coupling, design/type, DIN 15 170		similar to form H	similar to form H	similar to form H	similar to form H

1) With 150 mm free lift 2) For alternative masts, refer to tables 3) front/rear 4) Including a 200 mm (min.) operating aisle clearance 5) Power consumption with 45 working cycles per hour

TECHNICAL DATA (According to VDI 2198)

	Characteristics						
	1.1	Manufacturer		Linde	Linde	Linde	Linde
	1.2	Model		H70 T	H80 T	H80/900 T	H80/1100 T
	1.2a	Series		396-03	396-03	396-03	396-03
	1.3	Power unit		LPG	LPG	LPG	LPG
	1.4	Operation		Seat	Seat	Seat	Seat
	1.5	Load capacity/Load	Q (t)	7.0	8.0	8.0	8.0
	1.6	Load centre	c (mm)	600	600	900	1100
	1.8	Axle centre to fork face	x (mm)	640	640	670	680
	1.9	Wheelbase	y (mm)	2200	2200	2510	2810
Weights	2.1	Service weight	(kg)	11379	12210	13931	14748
	2.2	Axle load with load, front/rear	(kg)	15904/2475	17625/2585	19563/2368	20388/2360
	2.3	Axle load without load, front/rear	(kg)	4959/6420	5116/7094	6559/7372	7320/7428
Wheels/Tyres	3.1	Tyres rubber, SE, pneumatic, polyurethane		SE twin	SE twin	SE twin	SE twin
	3.2	Tyre size, front		8.25 - 15	8.25 - 15	8.25 - 15	315/70 - 15 (300 - 15)
	3.3	Tyre size, rear		315/70 - 15 (300 - 15)	315/70 - 15 (300 - 15)	315/70 - 15 (300 - 15)	315/70 - 15 (300 - 15)
	3.5	Wheels, number front/rear (x = driven)		4x/2	4x/2	4x/2	4x/2
	3.6	Track width, front	b10 (mm)	1742	1742	1742	1752
	3.7	Track width, rear	b11 (mm)	1550	1550	1550	1550
Dimensions	4.1	Mast/fork carriage tilt, forward/backward	a/b (°)	5.0/9.0	5.0/9.0	5.0/9.0	5.0/9.0
	4.2	Height of mast, lowered	h1 (mm)	2738 ¹⁾	2737 ¹⁾	2735 ¹⁾	2737 ¹⁾
	4.3	Free lift	h2 (mm)	150	150	150	150
	4.4	Lift	h3 (mm)	3150 ²⁾	3150 ²⁾	2750 ²⁾	2750 ²⁾
	4.5	Height of mast, extended	h4 (mm)	4245	4244	4144	4146
	4.7	Height of overhead guard (cabin)	h6 (mm)	2748	2746	2746	2747
	4.8	Seat height relative to SIP/stand height	h7 (mm)	1509	1508	1507	1508
	4.12	Towing coupling height	h10 (mm)	830	828	828	827
	4.19	Overall length	l1 (mm)	4729	4729	5629	6339
	4.20	Length to fork face	l2 (mm)	3529	3529	3829	4139
	4.21	Overall width	b1/b2 (mm)	2232/1870 ³⁾	2232/1870 ³⁾	2232/1870 ³⁾	2305/1870 ³⁾
	4.22	Fork dimensions DIN ISO 2331	s/e/l (mm)	70 × 150 × 1200	70 × 150 × 1200	70 × 200 × 1800	80 × 200 × 2200
	4.23	Fork carriage to ISO 2328, class/type A, B		4A	4A	4A	4A
	4.24	Width of fork carriage	b3 (mm)	1800	2180	2180	2400
	4.31	Ground clearance, below mast	m1 (mm)	208	204	201	208
	4.32	Ground clearance, centre of wheelbase	m2 (mm)	251	250	248	250
	4.33	Load dimension b12 × l6	b12 × l6 (mm)	-	-	2000 × 2200	2000 × 2200
	4.34	Aisle width predetermined load dimensions	Ast (mm)	-	-	6580	6930
	4.34.1	Aisle width for pallets 1000 × 1200 crossways	Ast (mm)	5026 ⁴⁾	5026 ⁴⁾	5380 ⁴⁾	5730 ⁴⁾
4.34.2	Aisle width with pallet 800 × 1200 along forks	Ast (mm)	5226 ⁴⁾	5226 ⁴⁾	5580 ⁴⁾	5930 ⁴⁾	
4.35	Turning radius	Wa (mm)	3186	3186	3510	3850	
4.36	Minimum pivoting point distance	b13 (mm)	1061	1061	1240	1410	
Performance	5.1	Travel speed, with/without load	(km/h)	22/23	22/23	22/23	22/23
	5.2	Lifting speed, with/without load	(m/s)	0.43/0.54	0.4/0.54	0.4/0.54	0.4/0.54
	5.3	Lowering speed, with/without load	(m/s)	0.56/0.48	0.56/0.48	0.56/0.48	0.56/0.48
	5.5	Tractive force, with/without load	(N)	50000/37000	51000/41000	52000/46000	54000/50000
	5.7	Climbing ability, with/without load	(%)	27.0/34.0	25.0/34.0	23.0/34.0	22.0/34.0
	5.9	Acceleration time, with/without load	(s)	6.6/5.6	6.8/5.8	7.0/6.0	7.2/6.2
5.10	Service brake		hydrostatic	hydrostatic	hydrostatic	hydrostatic	
IC-Drive	7.1	Engine manufacturer/type		VW CKPA	VW CKPA	VW CKPA	VW CKPA
	7.2	Engine performance according to DIN ISO 1585	(kW)	72	72	72	72
	7.3	Rated speed	(1/min)	2500	2500	2500	2500
	7.4	Number of cylinders/displacement	(-/cm ³)	6/3597	6/3597	6/3597	6/3597
	7.5	Fuel consumption according to DIN EN 16796	(l/h)	5.3 ⁵⁾	5.6 ⁵⁾	5.9 ⁵⁾	6.2 ⁵⁾
	7.5.1	CO ₂ equivalent according to EN 16796	kg/h	17.8	19	20	21
	7.6	Turnover output according to VDI 2198	t/h	483.0	533.0	520.0	512.0
	7.7	Turnover efficiency according to VDI 2198	t/l	58.9	64.2	62.7	61.7
Drive/Lift mechanism	8.1	Type of drive control		hydrost./stepl.	hydrost./stepl.	hydrost./stepl.	hydrost./stepl.
	10.1	Operating pressure for attachments	(bar)	265	265	265	265
	10.2	Oil flow for attachments	(l/min)	95	95	95	95
	10.7	Sound pressure level LpAZ (at the driver's seat)	(dB(A))	76	76	76	76
	10.8	Towing coupling, design/type, DIN 15 170		similar to form H	similar to form H	similar to form H	similar to form H

1) With 150 mm free lift 2) For alternative masts, refer to tables 3) front/rear 4) Including a 200 mm (min.) operating aisle clearance 5) Power consumption with 45 working cycles per hour

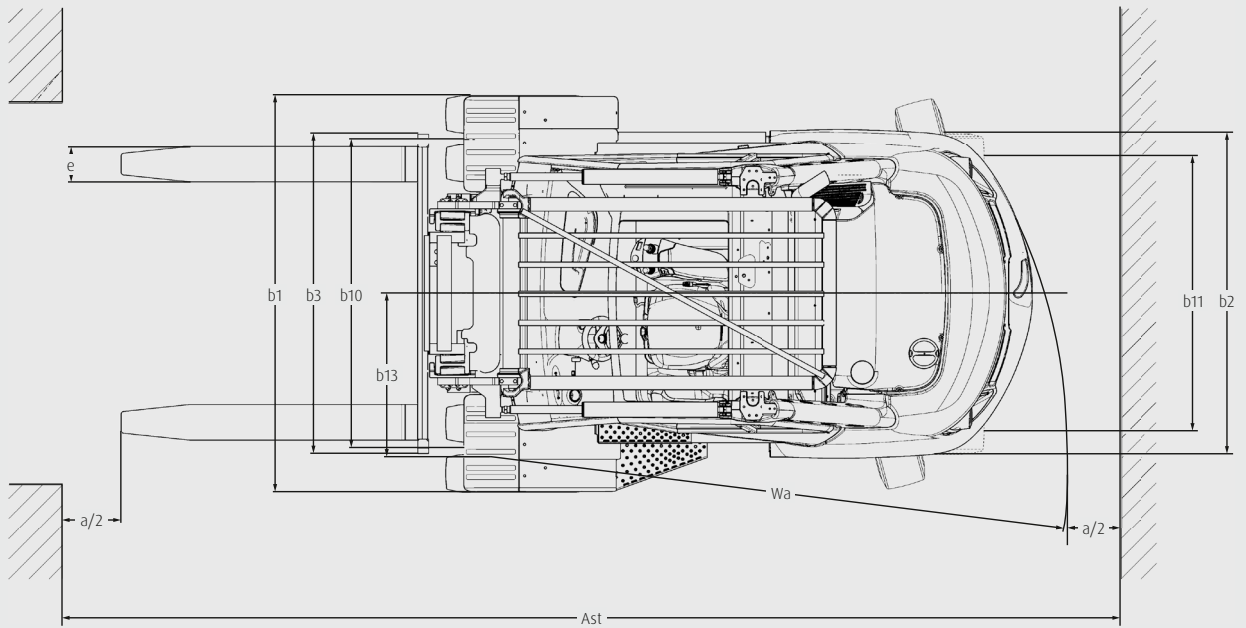
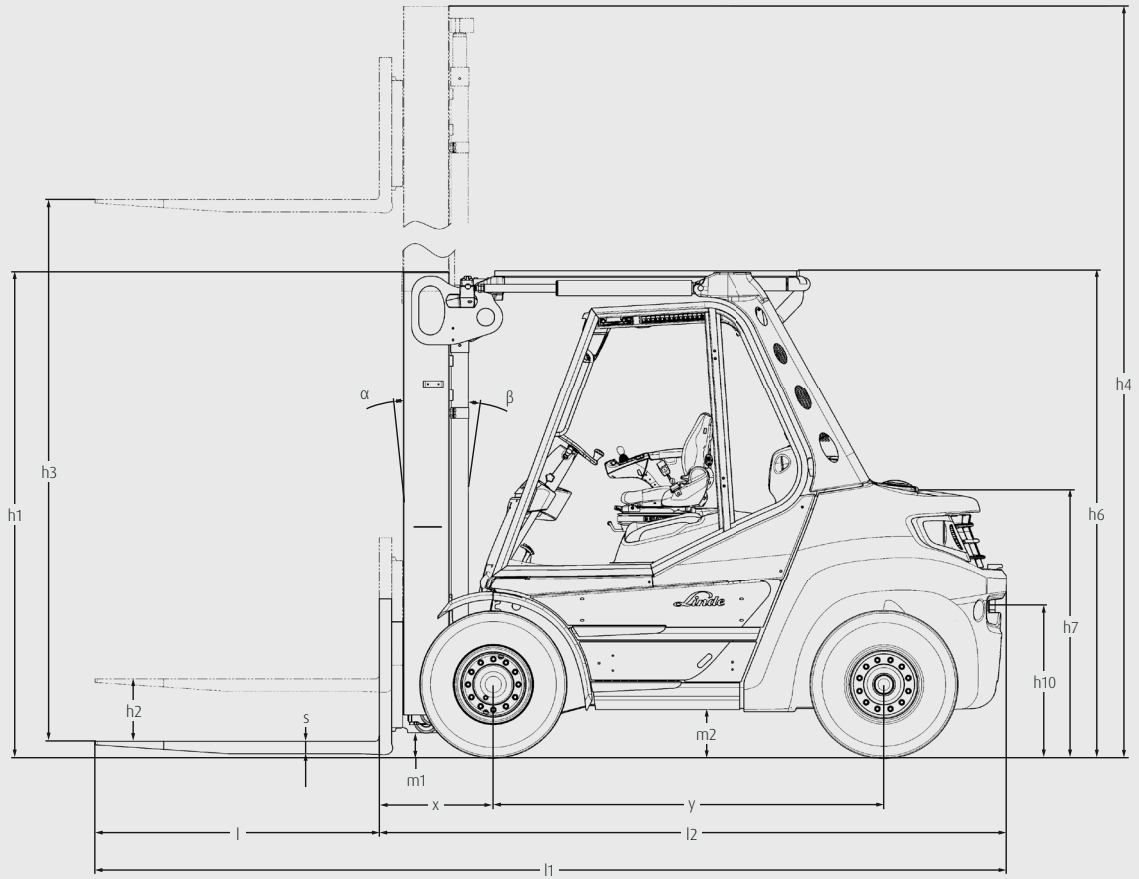

MAST TABLES

STANDARD MAST (in mm)

Series	195							
Lift	h3: 3550	h3: 3850	h3: 4150	h3: 4550	h3: 4850	h3: 5250	h3: 6050	
Height measurements	h1: 2735 h2: 150 h4: 4448	h1: 2885 h2: 150 h4: 4748	h1: 3035 h2: 150 h4: 5048	h1: 3235 h2: 150 h4: 5448	h1: 3385 h2: 150 h4: 5748	h1: 3585 h2: 150 h4: 6148	h1: 3985 h2: 150 h4: 6948	
Model								
H50	<input type="radio"/>	<input type="radio"/>	<input type="radio"/>	<input type="radio"/>	<input type="radio"/>	<input type="radio"/>	<input type="radio"/>	
H60	<input type="radio"/>	<input type="radio"/>	<input type="radio"/>	<input type="radio"/>	<input type="radio"/>	<input type="radio"/>	<input type="radio"/>	

Series	195							
Lift	h3: 3150	h3: 3450	h3: 3750	h3: 4150	h3: 4450	h3: 4850	h3: 5650	
Height measurements	h1: 2735 h2: 150 h4: 4243	h1: 2885 h2: 150 h4: 4543	h1: 3035 h2: 150 h4: 4843	h1: 3235 h2: 150 h4: 5243	h1: 3385 h2: 150 h4: 5543	h1: 3585 h2: 150 h4: 5943	h1: 3985 h2: 150 h4: 6743	
Model								
H70	<input type="radio"/>	<input type="radio"/>	<input type="radio"/>	<input type="radio"/>	<input type="radio"/>	<input type="radio"/>	<input type="radio"/>	
H80	<input type="radio"/>	<input type="radio"/>	<input type="radio"/>	<input type="radio"/>	<input type="radio"/>	<input type="radio"/>	<input type="radio"/>	

Series	195							
Lift	h3: 2750	h3: 3050	h3: 3350	h3: 3750	h3: 4050	h3: 4450	h3: 5250	
Height measurements	h1: 2735 h2: 150 h4: 4145	h1: 2885 h2: 150 h4: 4445	h1: 3035 h2: 150 h4: 4745	h1: 3235 h2: 150 h4: 5145	h1: 3385 h2: 150 h4: 5445	h1: 3585 h2: 150 h4: 5845	h1: 3985 h2: 150 h4: 6645	
Model								
H80/900	<input type="radio"/>	<input type="radio"/>	<input type="radio"/>	<input type="radio"/>	<input type="radio"/>	<input type="radio"/>	<input type="radio"/>	
H80/1100	<input type="radio"/>	<input type="radio"/>	<input type="radio"/>	<input type="radio"/>	<input type="radio"/>	<input type="radio"/>	<input type="radio"/>	

TRIPLEX MAST (in mm)

Series	195							
Lift	h3: 4770	h3: 5370	h3: 5820	h3: 6420	h3: 4705	h3: 5155	h3: 5605	
Height measurements	h1: 2712 h2: 1755 h4: 5662	h1: 2862 h2: 1905 h4: 6262	h1: 3012 h2: 2055 h4: 6712	h1: 3212 h2: 2255 h4: 7312	h1: 2708 h2: 1555 h4: 5793	h1: 2858 h2: 1705 h4: 6243	h1: 3008 h2: 1855 h4: 6693	
Model								
H50	<input type="radio"/>	<input type="radio"/>	<input type="radio"/>	<input type="radio"/>	–	–	–	
H60	<input type="radio"/>	<input type="radio"/>	<input type="radio"/>	<input type="radio"/>	–	–	–	
H70	–	–	–	–	<input type="radio"/>	<input type="radio"/>	<input type="radio"/>	
H80	–	–	–	–	<input type="radio"/>	<input type="radio"/>	<input type="radio"/>	

Series	195	
Lift	h3: 6205	h3: 7255
Height measurements	h1: 3208 h2: 2055 h4: 7293	h1: 3558 h2: 2405 h4: 8343
Model		
H50	–	–
H60	–	–
H70	<input type="radio"/>	<input type="radio"/>
H80	<input type="radio"/>	<input type="radio"/>

Series	195							
Lift	h3: 3955	h3: 4405	h3: 4855	h3: 5455	h3: 5905	h3: 7105	h3: 7705	
Height measurements	h1: 2712 h2: 1255 h4: 5347	h1: 2862 h2: 1405 h4: 5797	h1: 3012 h2: 1555 h4: 6247	h1: 3212 h2: 1755 h4: 6847	h1: 3362 h2: 1905 h4: 7297	h1: 3762 h2: 2305 h4: 8497	h1: 3962 h2: 2505 h4: 9097	
Model								
H80/900	<input type="radio"/>	<input type="radio"/>	<input type="radio"/>	<input type="radio"/>	<input type="radio"/>	<input type="radio"/>	<input type="radio"/>	
H80/1100	<input type="radio"/>	<input type="radio"/>	<input type="radio"/>	<input type="radio"/>	<input type="radio"/>	<input type="radio"/>	<input type="radio"/>	

○ Optional equipment

– Not available

h1: Height of mast, lowered

h2: Free lift

h3: Lift

h4: Height of mast, extended

LOAD CAPACITY

H50

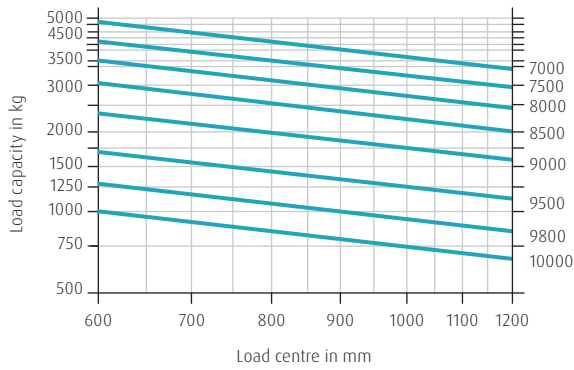

H60

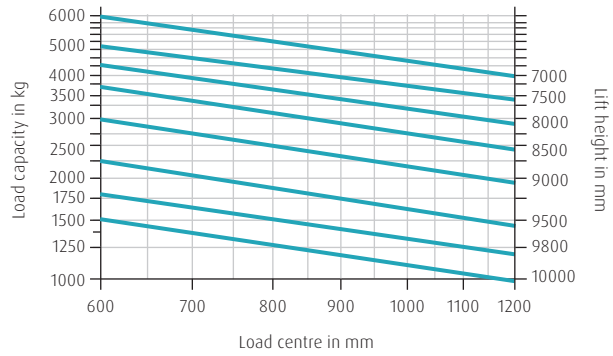

H70

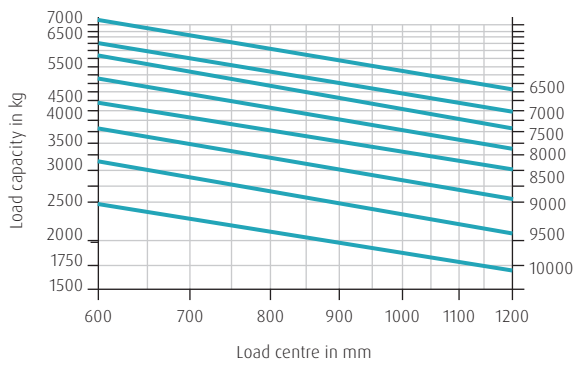

H80

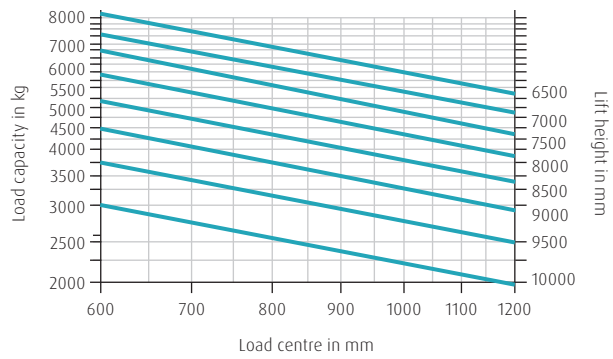

H80 / 900

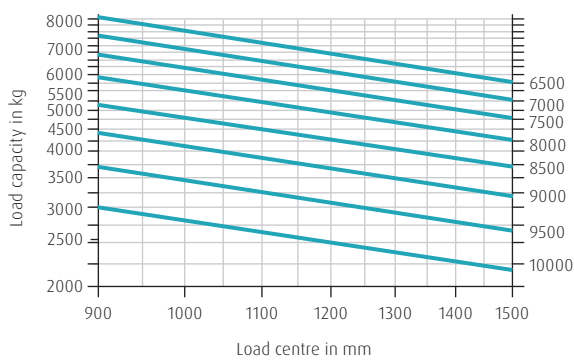

H80 / 1100

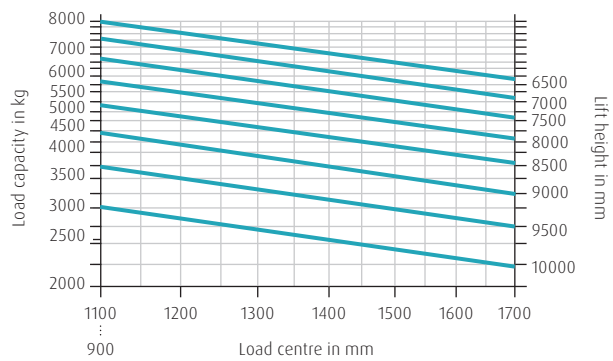

STANDARD AND OPTIONAL EQUIPMENT

Model/Equipment		H50 - H80 / 1100 D	H50 - H80 / 1100 T
Workplace	Ergonomic, safe truck access due low entry step and handle bar at a-pillar and bonnet	●	●
	Innovative decoupling concept for lowest human vibrations	●	●
	Tilt-adjustable steering column	●	●
	Interior light	●	●
	12-volt socket	●	●
	Overhead guard comfort for maximum head clearance	●	●
	Operator's seat - mechanical quick weight adjustment	●	●
	Various seating options such as heating, air suspension, active seat ventilation, longitudinal suspension	○	○
	Operator's seat - swiveling seat	○	○
	Glare-free display, control lights for all major functions	●	●
	Top screen armoured glass	○	○
	Cabin doors with openable window	○	○
	Din A4 illuminated clipboard	○	○
	Warm water heater / air condition including defog function and rear window heater	○	○
Radio, DAB+, MP3 Player including bluetooth hands-free equipment	○	○	
Drive and Brake System	Linde Hydrostatic Drive - for high productivity and low fuel consumption	●	●
	Deutz Diesel Engine EU 2016 / 1628 Stage 5*	●	—
	DEF - injection (AdBlue®), particle filter, oxidation catalysts, exhaust gas recirculation	●	—
	Volkswagen LPG engine including 3-way catalyst	—	○
	LPG tank including fill-level indicator in the display	—	●
	Engine air filter including safety elements	●	●
	Linde Engine Protection System (LEPS) - warning, speed reduction under critical engine conditions	●	●
	Hydraulic parking brake	●	●
	Oversized, variable displacement pump for lifting function - for low fuel consumption, low noise level and emissions	●	●
	Hydraulic filter concept - realising 6000 hour hydraulic-oil change interval	●	●
Power settings: efficiency, economy, performance	●	●	
Axles and Tyres	Super Elastic (SE) tyres	●	●
	Closed Shoulder tyres CS 20	○	○
	Pneumatic tyres	○	○
	Antistatic, non-marking tyres	○	○
	Anti-spray mudflaps front and rear	○	○
Mast	Linde Torsion Support System reduces torsional stress	●	●
	Top-mounted tilting cylinders	●	●
	Optimal visibility with nested mast profiles on standard and triplex masts	●	●
	Electronic damped tilt stop	●	●
Hydraulic accumulator for high driving comfort and less wear	○	○	
Attachment / Forks	Reinforced Linde forks - easily adjustable with a long service life	○	○
	Different integrated attachments	○	○
	Street sweeper preparation	○	○
Safety	Linde Curve Assist - automatic drive speed reduction when cornering	●	●
	Electrical seat belt monitoring - visual and acoustic feedback	●	●
	BlueSpot and TruckSpot - optical warning signal for pedestrians and drivers	○	○
	Load weight indicator including assistance function	○	○
	Linde Safety Pilot - load-dependent travel and lifting speed intervention plus additional functions	○	○
	Linde Safety Guard - truck-to-truck warning and truck-to-pedestrian warning	○	○
Speed limitations (via switch, indoor-outdoor, load depending)	○	○	
Digitalisation	Data Transmission Online	○	○
	Data Transmission Wifi	○	○
	Linde connect:desk - local fleet management with different functional modules	○	○
	Linde connect:cloud - fleet management as a service (hosted version)	○	○
	Pre-Operation Check - individualisable daily check protocol for operational readiness	○	○
Truck Call App - coordination of transport orders	○	○	
Operation / Load Handling	Double pedal control - stepless acceleration and fast reversing	●	●
	Single-pedal control - stepless acceleration	○	○
	Linde Load Control - central levers fully integrated in the armrest for precise control of all hydraulic functions	●	●
	Individual Lever System	○	○

● Standard equipment ○ Optional equipment — Not available

* EPA / CARB Stage 4 Final

CHARACTERISTICS



Suspended cab

Ergonomics

- Outstanding ergonomic operating concept
- Spacious cab with generous legroom, comfortable seats and smart layout of instruments
- Decoupled drive unit and suspended cab minimise vibration and provide healthy working conditions
- Simpler processes through forward or reverse travel with both pedals, and automatic stop if foot leaves pedal



Hydraulic direct drive

Handling

- Powerful and precise operation thanks to hydrostatic drive
- Fast, eco-friendly handling processes guaranteed by high-torque, fuel-efficient engines with low exhaust emissions
- Exact load handling by fingertip with Linde Load Control
- Exceptional residual capacity for transport of very heavy loads



Protective overhead guard

Safety

- Linde torsion support provides excellent stability and up to 30% reduction in lift mast rotations at high load heights
- Unrivalled operator safety thanks to Linde Protector Frame and roof guard against falling loads
- Increased safety via automatic speed reduction during cornering
- Slim lift mast results in optimum all-round visibility



Hydraulic oil change

Service

- Long maintenance intervals ensure maximum availability and minimal servicing costs
- First engine oil change and steering axle/mast lubrication not before 1000 operating hours
- Hydraulic oil change only after 6000 hours
- Absence of high-maintenance parts such as transmission, clutch and drum brakes further reduces service requirements

Presented by:

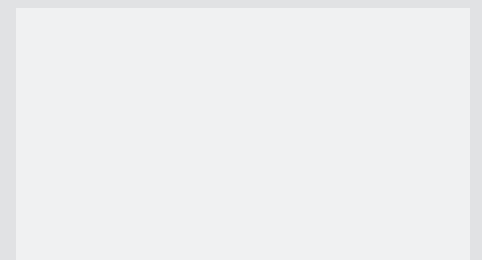

Subject to modification in the interest of progress. Illustrations and technical details could include options and are not binding for actual constructions. All dimensions subject to usual tolerances.



Linde Material Handling GmbH

Carl-von-Linde-Platz | 63743 Aschaffenburg | Germany
Phone + 49 6021 99 0 | Fax + 49 6021 99 1570
www.linde-mh.com | info@linde-mh.com

Printed in Germany | DS_H50_H80_396_03_en_M_0922